

**TEST PAPER OF JEE(MAIN) EXAMINATION – 2019**  
**(Held On Friday 11<sup>th</sup> JANUARY, 2019) TIME : 02 : 30 PM To 05 : 30 PM**  
**PHYSICS**

1. A paramagnetic substance in the form of a cube with sides 1 cm has a magnetic dipole moment of  $20 \times 10^{-6}$  J/T when a magnetic intensity of  $60 \times 10^3$  A/m is applied. Its magnetic susceptibility is :-

- (1)  $2.3 \times 10^{-2}$                       (2)  $3.3 \times 10^{-2}$   
 (3)  $3.3 \times 10^{-4}$                       (4)  $4.3 \times 10^{-2}$

**Ans. (3)**

**Sol.**  $\chi = \frac{I}{H}$

$I = \frac{\text{Magnetic moment}}{\text{Volume}}$

$I = \frac{20 \times 10^{-6}}{10^{-6}} = 20 \text{ N/m}^2$

$\chi = \frac{20}{60 \times 10^3} = \frac{1}{3} \times 10^{-3}$

$= 0.33 \times 10^{-3} = 3.3 \times 10^{-4}$

2. A particle of mass  $m$  is moving in a straight line with momentum  $p$ . Starting at time  $t = 0$ , a force  $F = kt$  acts in the same direction on the moving particle during time interval  $T$  so that its momentum changes from  $p$  to  $3p$ . Here  $k$  is a constant. The value of  $T$  is :-

- (1)  $2\sqrt{\frac{p}{k}}$     (2)  $\sqrt{\frac{2p}{k}}$     (3)  $\sqrt{\frac{2k}{p}}$     (4)  $2\sqrt{\frac{k}{p}}$

**Ans. (1)**

**Sol.**  $\frac{dp}{dt} = F = kt$

$\int_p^{3p} dP = \int_0^T kt \, dt$

$2p = \frac{KT^2}{2}$

$T = 2\sqrt{\frac{p}{K}}$

3. Seven capacitors, each of capacitance  $2 \mu\text{F}$ , are to be connected in a configuration to obtain an effective capacitance of  $\left(\frac{6}{13}\right) \mu\text{F}$ . Which of

the combinations, shown in figures below, will achieve the desired value ?

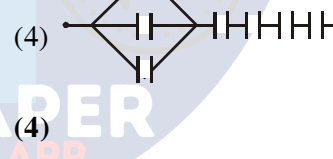
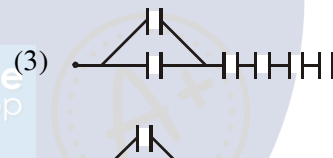
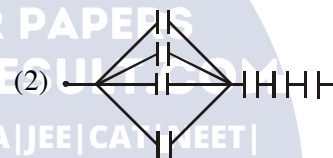
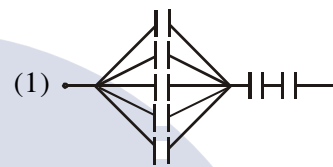

**Ans. (4)**

**Sol.**  $C_{eq} = \frac{6}{13} \mu\text{F}$

Therefore three capacitors must be in parallel to get  $6$  in

$\frac{1}{C_{eq}} = \frac{1}{3C} + \frac{1}{C} + \frac{1}{C} + \frac{1}{C} + \frac{1}{C}$

$C_{eq} = \frac{3C}{13} = \frac{6}{13} \mu\text{F}$

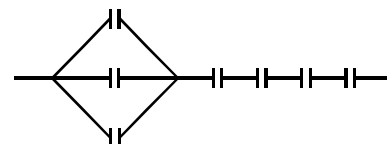

4. An electric field of 1000 V/m is applied to an electric dipole at angle of  $45^\circ$ . The value of electric dipole moment is  $10^{-29}$  C.m. What is the potential energy of the electric dipole ?

- (1)  $-9 \times 10^{-20}$  J
- (2)  $-7 \times 10^{-27}$  J
- (3)  $-10 \times 10^{-29}$  J
- (4)  $-20 \times 10^{-18}$  J

Ans. (2)

Sol.  $U = -\vec{p} \cdot \vec{E}$   
 $= -PE \cos \theta$   
 $= -(10^{-29})(10^3) \cos 45^\circ$   
 $= -0.707 \times 10^{-26}$  J  
 $= -7 \times 10^{-27}$  J.

5. A simple pendulum of length 1 m is oscillating with an angular frequency 10 rad/s. The support of the pendulum starts oscillating up and down with a small angular frequency of 1 rad/s and an amplitude of  $10^{-2}$  m. The relative change in the angular frequency of the pendulum is best given by :-

- (1)  $10^{-3}$  rad/s
- (2)  $10^{-1}$  rad/s
- (3) 1 rad/s
- (4)  $10^{-5}$  rad/s

Ans. (1)

Sol. Angular frequency of pendulum

$$\omega = \sqrt{\frac{g_{\text{eff}}}{\ell}}$$

$$\therefore \frac{\Delta\omega}{\omega} = \frac{1}{2} \frac{\Delta g_{\text{eff}}}{g_{\text{eff}}}$$

$$\Delta\omega = \frac{1}{2} \frac{\Delta g}{g} \times \omega$$

$[\omega_s = \text{angular frequency of support}]$

$$\Delta\omega = \frac{1}{2} \times \frac{2A\omega_s^2}{100} \times 100$$

$$\Delta\omega = 10^{-3} \text{ rad/sec.}$$

6. Two rods A and B of identical dimensions are at temperature  $30^\circ\text{C}$ . If A is heated upto  $180^\circ\text{C}$  and B upto  $T^\circ\text{C}$ , then the new lengths are the same. If the ratio of the coefficients of linear expansion of A and B is 4 : 3, then the value of T is :-

- (1)  $270^\circ\text{C}$
- (2)  $230^\circ\text{C}$
- (3)  $250^\circ\text{C}$
- (4)  $200^\circ\text{C}$

Ans. (2)

Sol.  $\Delta\ell_1 = \Delta\ell_2$

$$\ell\alpha_1\Delta T_1 = \ell\alpha_2\Delta T_2$$

$$\frac{\alpha_1}{\alpha_2} = \frac{\Delta T_1}{\Delta T_2}$$

$$\frac{4}{3} = \frac{T - 30}{180 - 30}$$

$$\boxed{T = 230^\circ\text{C}}$$

7. In a double-slit experiment, green light ( $5303 \text{ \AA}$ ) falls on a double slit having a separation of  $19.44 \mu\text{m}$  and a width of  $4.05 \mu\text{m}$ . The number of bright fringes between the first and the second diffraction minima is :-

- (1) 09
- (2) 10
- (3) 04
- (4) 05

Ans. (4)

Sol. For diffraction

location of 1<sup>st</sup> minima

$$y_1 = \frac{D\lambda}{a} = 0.2469D\lambda$$

location of 2<sup>nd</sup> minima

$$y_2 = \frac{2D\lambda}{a} = 0.4938D\lambda$$

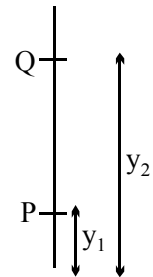

Now for interference

Path difference at P.

$$\frac{dy}{D} = 4.8\lambda$$

path difference at Q

$$\frac{dy}{D} = 9.6\lambda$$

So orders of maxima in between P & Q is

5, 6, 7, 8, 9

So 5 bright fringes all present between P & Q.

8. An amplitude modulated signal is plotted below :-

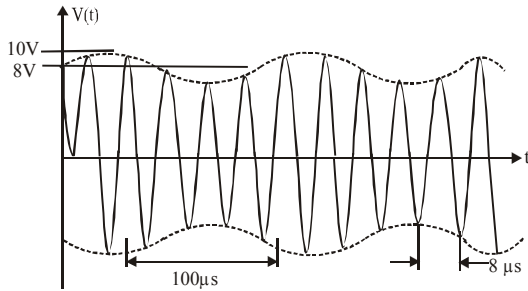

Which one of the following best describes the above signal ?

- (1)  $(9 + \sin(2.5\pi \times 10^5 t)) \sin(2\pi \times 10^4 t)V$   
 (2)  $(9 + \sin(4\pi \times 10^4 t)) \sin(5\pi \times 10^5 t)V$   
 (3)  $(1 + 9\sin(2\pi \times 10^4 t)) \sin(2.5\pi \times 10^5 t)V$   
 (4)  $(9 + \sin(2\pi \times 10^4 t)) \sin(2.5\pi \times 10^5 t)V$

Ans. (4)

Sol. Analysis of graph says

- (1) Amplitude varies as  $8 - 10 V$  or  $9 \pm 1$   
 (2) Two time period as  $100 \mu s$  (signal wave) &  $8 \mu s$  (carrier wave)

$$\text{Hence signal is } \left[ 9 \pm 1 \sin\left(\frac{2\pi t}{T_1}\right) \right] \sin\left(\frac{2\pi t}{T_2}\right)$$

$$= 9 \pm 1 \sin(2\pi \times 10^4 t) \sin 2.5\pi \times 10^5 t$$

9. In the circuit, the potential difference between A and B is :-

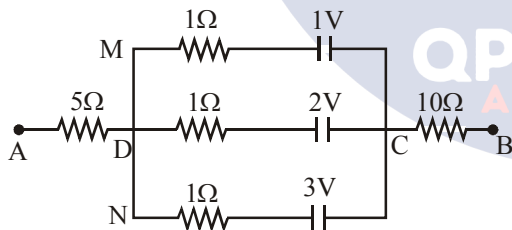

- (1) 6 V    (2) 1 V    (3) 3 V    (4) 2 V

Ans. (4)

Sol. Potential difference across AB will be equal to battery equivalent across CD

$$V_{AB} = V_{CD} = \frac{\frac{E_1}{r_1} + \frac{E_2}{r_2} + \frac{E_3}{r_3}}{\frac{1}{r_1} + \frac{1}{r_2} + \frac{1}{r_3}} = \frac{\frac{1}{1} + \frac{2}{1} + \frac{3}{1}}{\frac{1}{1} + \frac{1}{1} + \frac{1}{1}}$$

$$= \frac{6}{3} = 2V$$

10. A 27 mW laser beam has a cross-sectional area of  $10 \text{ mm}^2$ . The magnitude of the maximum electric field in this electromagnetic wave is given by [Given permittivity of space  $\epsilon_0 = 9 \times 10^{-12} \text{ SI units}$ , Speed of light  $c = 3 \times 10^8 \text{ m/s}$ ]:-

- (1) 1 kV/m                      (2) 2 kV/m  
 (3) 1.4 kV/m                  (4) 0.7 kV/m

Ans. (3)

Sol. Intensity of EM wave is given by

$$I = \frac{\text{Power}}{\text{Area}} = \frac{1}{2} \epsilon_0 E_0^2 C$$

$$= \frac{27 \times 10^{-3}}{10 \times 10^{-6}} = \frac{1}{2} \times 9 \times 10^{-12} \times E^2 \times 3 \times 10^8$$

$$E = \sqrt{2} \times 10^3 \text{ kv/m} \\ = 1.4 \text{ kv/m}$$

11. A pendulum is executing simple harmonic motion and its maximum kinetic energy is  $K_1$ . If the length of the pendulum is doubled and it performs simple harmonic motion with the same amplitude as in the first case, its maximum kinetic energy is  $K_2$ . Then :-

- (1)  $K_2 = \frac{K_1}{4}$                       (2)  $K_2 = \frac{K_1}{2}$   
 (3)  $K_2 = 2K_1$                   (4)  $K_2 = K_1$

Ans. (3)

Sol. Maximum kinetic energy at lowest point B is given by

$$K = mgl(1 - \cos \theta)$$

where  $\theta =$  angular amp.

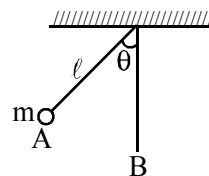

$$K_1 = mgl(1 - \cos \theta)$$

$$K_2 = mg(2l)(1 - \cos \theta)$$

$$K_2 = 2K_1.$$

12. In a hydrogen like atom, when an electron jumps from the M - shell to the L - shell, the wavelength of emitted radiation is  $\lambda$ . If an electron jumps from N-shell to the L-shell, the wavelength of emitted radiation will be :-

- (1)  $\frac{27}{20}\lambda$  (2)  $\frac{16}{25}\lambda$  (3)  $\frac{20}{27}\lambda$  (4)  $\frac{25}{16}\lambda$

**Ans. (3)**

**Sol.** For M  $\rightarrow$  L steel

$$\frac{1}{\lambda} = K \left( \frac{1}{2^2} - \frac{1}{3^2} \right) = \frac{K \times 5}{36}$$

for N  $\rightarrow$  L

$$\frac{1}{\lambda'} = K \left( \frac{1}{2^2} - \frac{1}{4^2} \right) = \frac{K \times 3}{16}$$

$$\lambda' = \frac{20}{27}\lambda$$

**13.** If speed (V), acceleration (A) and force (F) are considered as fundamental units, the dimension of Young's modulus will be :-

- (1)  $V^{-2} A^2 F^2$  (2)  $V^{-4} A^2 F$   
 (3)  $V^{-4} A^{-2} F$  (4)  $V^{-2} A^2 F^{-2}$

**Ans. (2)**

**Sol.**  $\frac{F}{A} = y \cdot \frac{\Delta \ell}{\ell}$

$$[Y] = \frac{F}{A}$$

Now from dimension

$$F = \frac{ML}{T^2}$$

$$L = \frac{F}{M} \cdot T^2$$

$$L^2 = \frac{F^2}{M^2} \left( \frac{V}{A} \right)^4 \therefore T = \frac{V}{A}$$

$$L^2 = \frac{F^2}{M^2 A^2} \frac{V^4}{A^2} \quad F = MA$$

$$L^2 = \frac{V^4}{A^2}$$

$$[Y] = \frac{[F]}{[A]} = F^1 V^{-4} A^2$$

**14.** A particle moves from the point  $(2.0\hat{i} + 4.0\hat{j})$  m, at  $t = 0$ , with an initial velocity  $(5.0\hat{i} + 4.0\hat{j})$   $\text{ms}^{-1}$ .

It is acted upon by a constant force which produces a constant acceleration  $(4.0\hat{i} + 4.0\hat{j})$   $\text{ms}^{-2}$ . What is the distance of the particle from the origin at time 2 s ?

- (1)  $20\sqrt{2}$  m (2)  $10\sqrt{2}$  m  
 (3) 5 m (4) 15 m

**Ans. (1)**

**Sol.**  $\vec{S} = (5\hat{i} + 4\hat{j})2 + \frac{1}{2}(4\hat{i} + 4\hat{j})4$

$$= 10\hat{i} + 8\hat{j} + 8\hat{i} + 8\hat{j}$$

$$\vec{r}_f - \vec{r}_i = 18\hat{i} + 16\hat{j}$$

$$\vec{r}_f = 20\hat{i} + 20\hat{j}$$

$$|\vec{r}_f| = 20\sqrt{2}$$

**15.** A monochromatic light is incident at a certain angle on an equilateral triangular prism and suffers minimum deviation. If the refractive index of the material of the prism is  $\sqrt{3}$ , then the angle of incidence is :-

- (1)  $30^\circ$  (2)  $45^\circ$   
 (3)  $90^\circ$  (4)  $60^\circ$

**Ans. (4)**

**Sol.**  $i = e$

$$r_1 = r_2 = \frac{A}{2} = 30^\circ$$

by Snell's law

$$1 \times \sin i = \sqrt{3} \times \frac{1}{2} = \frac{\sqrt{3}}{2}$$

$$i = 60$$

**16.** A galvanometer having a resistance of  $20 \Omega$  and 30 divisions on both sides has figure of merit 0.005 ampere/division. The resistance that should be connected in series such that it can be used as a voltmeter upto 15 volt, is :-

- (1)  $80 \Omega$  (2)  $120 \Omega$   
 (3)  $125 \Omega$  (4)  $100 \Omega$

**Ans. (1)**

**Sol.**  $R_g = 20\Omega$

$N_L = N_R = N = 30$

FOM =  $\frac{I}{\phi} = 0.005 \text{ A/Div.}$

Current sensitivity = CS =  $\left(\frac{1}{0.005}\right) = \frac{\phi}{I}$

$I_{g_{max}} = 0.005 \times 30$   
 $= 15 \times 10^{-2} = 0.15$

$15 = 0.15 [20 + R]$

$100 = 20 + R$

$R = 80$

- 17.** The circuit shown below contains two ideal diodes, each with a forward resistance of  $50\Omega$ . If the battery voltage is  $6 \text{ V}$ , the current through the  $100 \Omega$  resistance (in Amperes) is :-

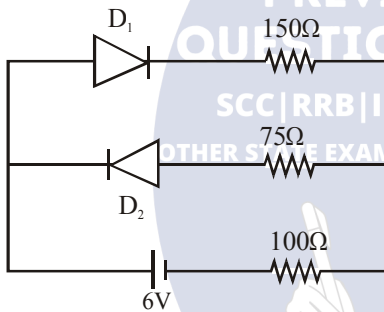

(1) 0.027

(3) 0.030

(2) 0.020

(4) 0.036

**Ans. (2)**

**Sol.**  $I = \frac{6}{300} = 0.002$  ( $D_2$  is in reverse bias)

- 18.** When  $100 \text{ g}$  of a liquid A at  $100^\circ\text{C}$  is added to  $50 \text{ g}$  of a liquid B at temperature  $75^\circ\text{C}$ , the temperature of the mixture becomes  $90^\circ\text{C}$ . The temperature of the mixture, if  $100 \text{ g}$  of liquid A at  $100^\circ\text{C}$  is added to  $50 \text{ g}$  of liquid B at  $50^\circ\text{C}$ , will be :-

(1)  $80^\circ\text{C}$

(2)  $60^\circ\text{C}$

(3)  $70^\circ\text{C}$

(4)  $85^\circ\text{C}$

**Ans. (1)**

**Sol.**  $100 \times S_A \times [100 - 90] = 50 \times S_B \times (90 - 75)$

$2S_A = 1.5 S_B$

$S_A = \frac{3}{4} S_B$

Now,  $100 \times S_A \times [100 - T] = 50 \times S_B (T - 50)$

$2 \times \left(\frac{3}{4}\right) (100 - T) = (T - 50)$

$300 - 3T = 2T - 100$

$400 = 5T$

$T = 80$

- 19.** The mass and the diameter of a planet are three times the respective values for the Earth. The period of oscillation of a simple pendulum on the Earth is  $2 \text{ s}$ . The period of oscillation of the same pendulum on the planet would be :-

(1)  $\frac{2}{\sqrt{3}} \text{ s}$

(2)  $2\sqrt{3} \text{ s}$

(3)  $\frac{\sqrt{3}}{2} \text{ s}$

(4)  $\frac{3}{2} \text{ s}$

**Ans. (2)**

**Sol.**  $\therefore g = \frac{GM}{R^2}$

$\frac{g_p}{g_e} = \frac{M_e \left(\frac{R_e}{R_p}\right)^2}{M_e \left(\frac{R_e}{R_p}\right)^2} = 3 \left(\frac{1}{3}\right)^2 = \frac{1}{3}$

Also  $T \propto \frac{1}{\sqrt{g}}$

$\Rightarrow \frac{T_p}{T_e} = \sqrt{\frac{g_e}{g_p}} = \sqrt{3}$

$\Rightarrow T_p = 2\sqrt{3} \text{ s}$

- 20.** The region between  $y = 0$  and  $y = d$  contains a magnetic field  $\vec{B} = B\hat{z}$ . A particle of mass  $m$  and charge  $q$  enters the region with a velocity

$\vec{v} = v\hat{i}$ . If  $d = \frac{mv}{2qB}$ , the acceleration of the

charged particle at the point of its emergence at the other side is :-

- (1)  $\frac{qvB}{m} \left( \frac{\hat{i} + \hat{j}}{\sqrt{2}} \right)$       (2)  $\frac{qvB}{m} \left( \frac{1}{2} \hat{i} - \frac{\sqrt{3}}{\sqrt{2}} \hat{j} \right)$   
 (3)  $\frac{qvB}{m} \left( \frac{-\hat{j} + \hat{i}}{\sqrt{2}} \right)$       (4)  $\frac{qvB}{m} \left( \frac{\sqrt{3}}{2} \hat{i} + \frac{1}{2} \hat{j} \right)$

Ans. (BONUS)

Sol.

In equation, entry point of particle is not given

Assuming particle center from (0, d)

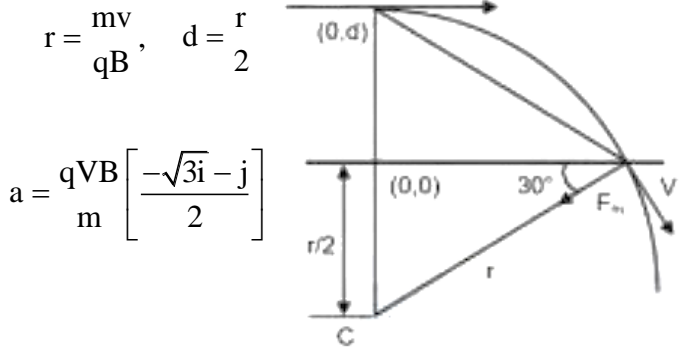

This option is not given in all above four choices.

21. A thermometer graduated according to a linear scale reads a value  $x_0$  when in contact with boiling water, and  $x_0/3$  when in contact with ice.

What is the temperature of an object in  $0^\circ\text{C}$ , if this thermometer in the contact with the object reads  $x_0/2$  ?

- (1) 35      (2) 25  
 (3) 60      (4) 40

Ans. (2)

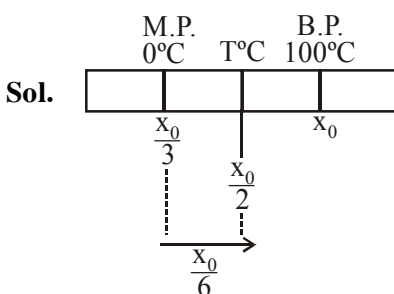

$$\Rightarrow T^\circ\text{C} = \frac{x_0}{6} \quad \& \quad \left( x_0 - \frac{x_0}{3} \right) = (100 - 0^\circ\text{C})$$

$$x_0 = \frac{300}{2}$$

$$\Rightarrow T^\circ\text{C} = \frac{150}{6} = 25^\circ\text{C}$$

22. A string is wound around a hollow cylinder of mass 5 kg and radius 0.5 m. If the string is now pulled with a horizontal force of 40 N, and the cylinder is rolling without slipping on a horizontal surface (see figure), then the angular acceleration of the cylinder will be (Neglect the mass and thickness of the string) :-

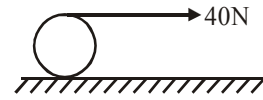

- (1)  $12 \text{ rad/s}^2$       (2)  $16 \text{ rad/s}^2$   
 (3)  $10 \text{ rad/s}^2$       (4)  $20 \text{ rad/s}^2$

Ans. (2)

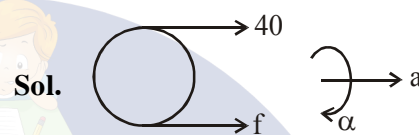

$$40 + f = m(R\alpha) \dots\dots (i)$$

$$40 \times R - f \times R = mR^2\alpha$$

$$40 - f = mR\alpha \dots\dots (ii)$$

From (i) and (ii)

$$\alpha = \frac{40}{mR} = 16$$

23. In a process, temperature and volume of one mole of an ideal monoatomic gas are varied according to the relation  $VT = K$ , where K is a constant. In this process the temperature of the gas is increased by  $\Delta T$ . The amount of heat absorbed by gas is (R is gas constant) :

- (1)  $\frac{1}{2}R\Delta T$       (2)  $\frac{3}{2}R\Delta T$

- (3)  $\frac{1}{2}KR\Delta T$       (4)  $\frac{2K}{3}\Delta T$

Ans. (1)

Sol.  $VT = K$

$$\Rightarrow V \left( \frac{PV}{nR} \right) = k \Rightarrow PV^2 = K$$

$$\therefore C = \frac{R}{1-x} + C_v \quad (\text{For polytropic process})$$

$$C = \frac{R}{1-2} + \frac{3R}{2} = \frac{R}{2}$$

$$\therefore \Delta Q = nC \Delta T$$

$$= \frac{R}{2} \times \Delta T$$

24. In a photoelectric experiment, the wavelength of the light incident on a metal is changed from 300 nm to 400 nm. The decrease in the stopping

potential is close to :  $\left( \frac{hc}{e} = 1240 \text{ nm} - V \right)$

- (1) 0.5 V (2) 1.0 V  
(3) 2.0 V (4) 1.5 V

Ans. (2)

Sol.  $\frac{hc}{\lambda_1} = \phi + eV_1$  ..... (i)

$\frac{hc}{\lambda_2} = \phi + eV_2$  ..... (ii)

(i) - (ii)

$$hc \left( \frac{1}{\lambda_1} - \frac{1}{\lambda_2} \right) = e(V_1 - V_2)$$

$$\Rightarrow V_1 - V_2 = \frac{hc}{e} \left( \frac{\lambda_2 - \lambda_1}{\lambda_1 \lambda_2} \right)$$

$$= (1240 \text{ nm} - V) \frac{100 \text{ nm}}{300 \text{ nm} \times 400 \text{ nm}}$$

$$= 1 \text{ V}$$

25. A metal ball of mass 0.1 kg is heated upto 500°C and dropped into a vessel of heat capacity 800 JK<sup>-1</sup> and containing 0.5 kg water. The initial temperature of water and vessel is 30°C. What is the approximate percentage increment in the temperature of the water ? [Specific Heat Capacities of water and metal are, respectively, 4200 Jkg<sup>-1</sup>K<sup>-1</sup> and 400 Jkg<sup>-1</sup>K<sup>-1</sup>]

- (1) 30% (2) 20%  
(3) 25% (4) 15%

Ans. (2)

Sol.  $0.1 \times 400 \times (500 - T) = 0.5 \times 4200 \times (T - 30) + 800 (T - 30)$

$$\Rightarrow 40(500 - T) = (T - 30) (2100 + 800)$$

$$\Rightarrow 20000 - 40T = 2900 T - 30 \times 2900$$

$$\Rightarrow 20000 + 30 \times 2900 = T(2940)$$

$$T = 30.4^\circ\text{C}$$

$$\frac{\Delta T}{T} \times 100 = \frac{6.4}{30} \times 100$$

$$\approx 20\%$$

26. The magnitude of torque on a particle of mass 1kg is 2.5 Nm about the origin. If the force acting on it is 1 N, and the distance of the particle from the origin is 5m, the angle between the force and the position vector is (in radians) :-

- (1)  $\frac{\pi}{8}$  (2)  $\frac{\pi}{6}$  (3)  $\frac{\pi}{4}$  (4)  $\frac{\pi}{3}$

Ans. (2)

Sol.  $2.5 = 1 \times 5 \sin \theta$

$$\sin \theta = 0.5 = \frac{1}{2}$$

$$\theta = \frac{\pi}{6}$$

27. In the experimental set up of metre bridge shown in the figure, the null point is obtained at a distance of 40 cm from A. If a 10Ω resistor is connected in series with R<sub>1</sub>, the null point shifts by 10 cm. The resistance that should be connected in parallel with (R<sub>1</sub> + 10)Ω such that the null point shifts back to its initial position is

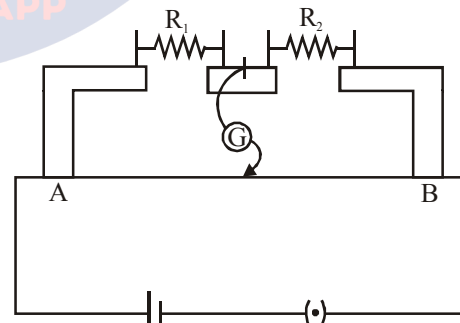

- (1) 40 Ω (2) 60 Ω (3) 20 Ω (4) 30 Ω

Ans. (2)

Sol.  $\frac{R_1}{R_2} = \frac{2}{3}$  .....(i)

$\frac{R_1 + 10}{R_2} = 1 \Rightarrow R_1 + 10 = R_2$  .....(ii)

$\frac{2R_2}{3} + 10 = R_2$

$10 = \frac{R_2}{3} \Rightarrow R_2 = 30\Omega$

&  $R_1 = 20\Omega$

$\frac{30 \times R}{30 + R} = \frac{2}{3}$

$R = 60 \Omega$

28. A circular disc  $D_1$  of mass  $M$  and radius  $R$  has two identical discs  $D_2$  and  $D_3$  of the same mass  $M$  and radius  $R$  attached rigidly at its opposite ends (see figure). The moment of inertia of the system about the axis  $OO'$ , passing through the centre of  $D_1$ , as shown in the figure, will be:-

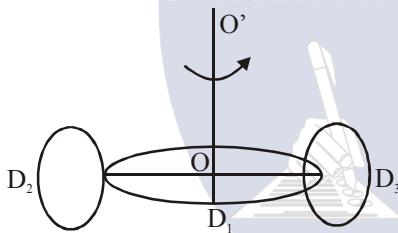

- (1)  $3MR^2$  (2)  $\frac{2}{3}MR^2$   
 (3)  $MR^2$  (4)  $\frac{4}{5}MR^2$

Ans. (1)

Sol.  $I = \frac{MR^2}{2} + 2\left(\frac{MR^2}{4} + MR^2\right)$   
 $= \frac{MR^2}{2} + \frac{MR^2}{2} + 2MR^2$   
 $= 3MR^2$

29. A copper wire is wound on a wooden frame, whose shape is that of an equilateral triangle. If the linear dimension of each side of the frame is increased by a factor of 3, keeping the number of turns of the coil per unit length of the frame the same, then the self inductance of the coil :

- (1) Decreases by a factor of  $9\sqrt{3}$   
 (2) Increases by a factor of 3  
 (3) Decreases by a factor of 9  
 (4) Increases by a factor of 27

Ans. (2)

Sol. Total length  $L$  will remain constant

$L = (3a) N$  ( $N =$  total turns)  
 and length of winding =  $(d) N$   
 ( $d =$  diameter of wire)

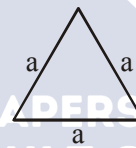

self inductance =  $\mu_0 n^2 A \ell$   
 $= \mu_0 n^2 \left(\frac{\sqrt{3} a^2}{4}\right) dN$   
 $\propto a^2 N \propto a$

So self inductance will become 3 times

30. A particle of mass  $m$  and charge  $q$  is in an electric and magnetic field given by

$\vec{E} = 2\hat{i} + 3\hat{j}$  ;  $\vec{B} = 4\hat{j} + 6\hat{k}$ .

The charged particle is shifted from the origin to the point  $P(x = 1 ; y = 1)$  along a straight path. The magnitude of the total work done is :-

- (1)  $(0.35)q$  (2)  $(0.15)q$   
 (3)  $(2.5)q$  (4)  $5q$

Ans. (4)

Sol.  $\vec{F}_{net} = q\vec{E} + q(\vec{v} \times \vec{B})$   
 $= (2q\hat{i} + 3q\hat{j}) + q(\vec{v} \times \vec{B})$   
 $W = \vec{F}_{net} \cdot \vec{S}$   
 $= 2q + 3q$   
 $= 5q$



**TEST PAPER OF JEE(MAIN) EXAMINATION – 2019**  
**(Held On Friday 11<sup>th</sup> JANUARY, 2019) TIME : 02 : 30 PM To 05 : 30 PM**  
**CHEMISTRY**

1. The correct option with respect to the Pauling electronegativity values of the elements is :-  
 (1) Ga < Ge                      (2) Si < Al  
 (3) P > S                          (4) Te > Se

Ans. (1)

Sol.

B      C  
 Al     Si

Ga < Ge

Along the period electronegativity increases

2. The homopolymer formed from 4-hydroxybutanoic acid is :-

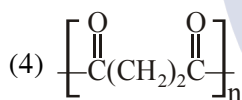
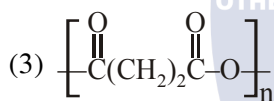
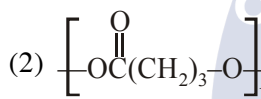
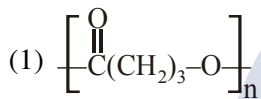

Ans. (1)

Sol.



3. The correct match between Item I and Item II is :-

Item I		Item II	
(A)	Ester test	(P)	Tyr
(B)	Carbylamine test	(Q)	Asp
(C)	Phthalein dye test	(R)	Ser
		(S)	Lys

- (1) (A)→(Q); (B)→(S); (C)→(P)  
 (2) (A)→(R); (B)→(Q); (C)→(P)  
 (3) (A)→(Q); (B)→(S); (C)→(R)  
 (4) (A)→(R); (B)→(S); (C)→(Q)

Ans. (1)

Sol.

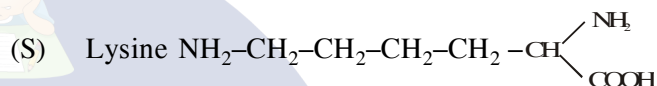
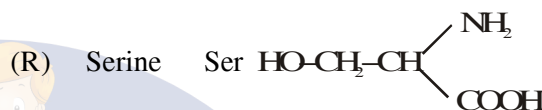
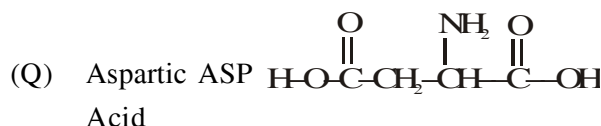
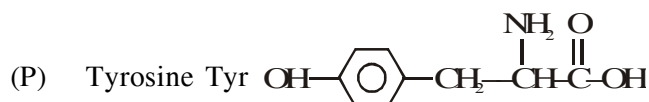

- (A) Ester test    (Q) Aspartic acid (Acidic amino acid)  
 (B) Carbylamine test    (S) Lysine [NH<sub>2</sub> group present]  
 (C) Phthalein dye test    (P) Tyrosine {Phenolic group present}

4. Taj Mahal is being slowly disfigured and discoloured. This is primarily due to :-  
 (1) Water pollution            (2) Global warming  
 (3) Soil pollution              (4) Acid rain

Ans. (4)

Sol. Taj mahal is slowly disfigured and discoloured due to acid rain.

5. The major product obtained in the following conversion is :-

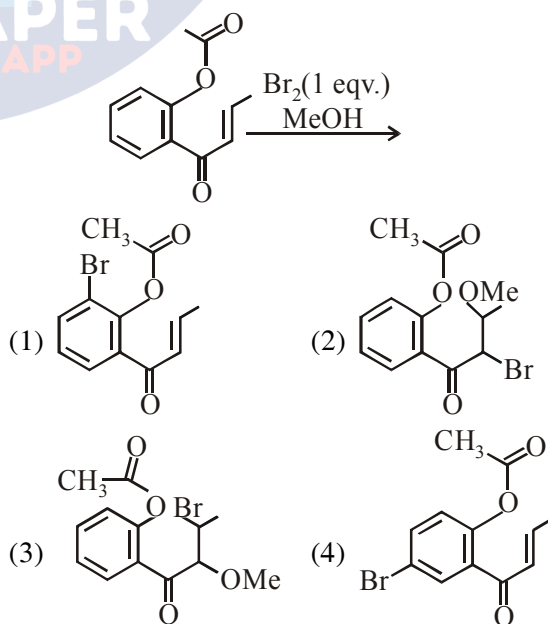

Ans. (2)

Sol.

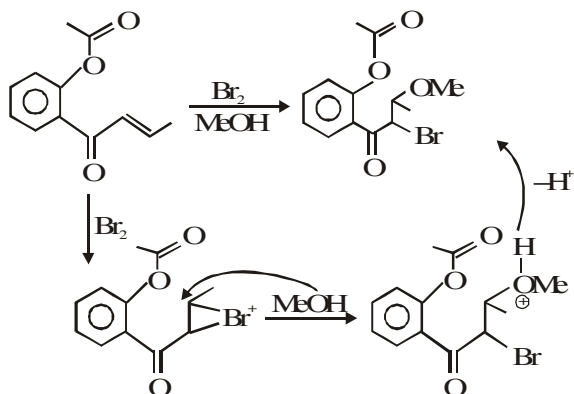

6. The number of bridging CO ligand (s) and Co-Co bond (s) in  $\text{Co}_2(\text{CO})_8$ , respectively are :-

- (1) 0 and 2                      (2) 2 and 0  
 (3) 4 and 0                      (4) 2 and 1

Ans. (4)

Sol.

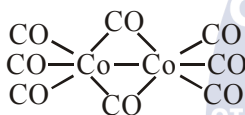

Bridging CO are 2 and Co - Co bond is 1.

7. In the following compound,

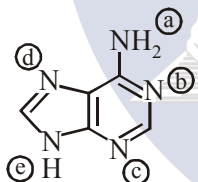

the favourable site/s for protonation is/are :-

- (1) (b), (c) and (d)              (2) (a)  
 (3) (a) and (e)                      (4) (a) and (d)

Ans. (1)

Sol. Localised lone pair  $e^-$ .

8. The higher concentration of which gas in air can cause stiffness of flower buds ?

- (1)  $\text{SO}_2$                                   (2)  $\text{NO}_2$   
 (3)  $\text{CO}_2$                                 (4) CO

Ans. (1)

Sol. Due to acid rain in plants high concentration of  $\text{SO}_2$  makes the flower buds stiff and makes them fall.

9. The correct match between item I and item II is :-

Item I		Item II	
(A)	Allosteric effect	(P)	Molecule binding to the active site of enzyme
(B)	Competitive inhibitor	(Q)	Molecule crucial for communication in the body
(C)	Receptor	(R)	Molecule binding to a site other than the active site of enzyme
(D)	Poison	(S)	Molecule binding to the enzyme covalently

- (1) (A)→(P); (B)→(R); (C)→(S); (D)→(Q)  
 (2) (A)→(R); (B)→(P); (C)→(S); (D)→(Q)  
 (3) (A)→(P); (B)→(R); (C)→(Q); (D)→(S)  
 (4) (A)→(R); (B)→(P); (C)→(Q); (D)→(S)

Ans. (4)

10. The radius of the largest sphere which fits properly at the centre of the edge of body centred cubic unit cell is : (Edge length is represented by 'a') :-

- (1) 0.134 a                              (2) 0.027 a  
 (3) 0.067 a                              (4) 0.047 a

Ans. (3)

Sol.

$$a = 2(R + r)$$

$$\frac{a}{2} = (R + r) \dots(1)$$

$$a\sqrt{3} = 4R \dots(2)$$

Using (1) & (2)

$$\frac{a}{2} = \frac{a\sqrt{3}}{4} = r$$

$$a \left( \frac{2 - \sqrt{3}}{4} \right) = r$$

$$r = 0.067 a$$

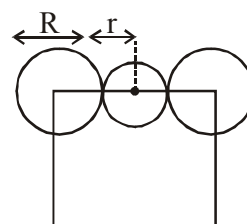

11. Among the colloids cheese (C), milk (M) and smoke (S), the correct combination of the dispersed phase and dispersion medium, respectively is :-

- (1) C : solid in liquid; M : solid in liquid; S : solid in gas
- (2) C : solid in liquid; M : liquid in liquid; S : gas in solid
- (3) C : liquid in solid; M : liquid in solid; S : solid in gas
- (4) C : liquid in solid; M : liquid in liquid; S : solid in gas

Ans. (4)

Sol.

	Dispersed Phase	Dispersion Medium
Cheese	Liquid	Solid
Milk	Liquid	Liquid
Smoke	Solid	Gas

12. The reaction that does NOT define calcination is:-

- (1)  $ZnCO_3 \xrightarrow{\Delta} ZnO + CO_2$
- (2)  $Fe_2O_3 \cdot xH_2O \xrightarrow{\Delta} Fe_2O_3 + xH_2O$
- (3)  $CaCO_3 \cdot MgCO_3 \xrightarrow{\Delta} CaO + MgO + 2 CO_2$
- (4)  $2 Cu_2S + 3 O_2 \xrightarrow{\Delta} 2 Cu_2O + 2 SO_2$

Ans. (4)

Sol. Calcination is carried out for carbonates and oxide ores in absence of oxygen. Roasting is carried out mainly for sulphide ores in presence of excess of oxygen.

13. The reaction,

$MgO(s) + C(s) \rightarrow Mg(S) + CO(g)$ , for which  $\Delta_r H^\circ = + 491.1 \text{ kJ mol}^{-1}$  and  $\Delta_r S^\circ = 198.0 \text{ JK}^{-1} \text{ mol}^{-1}$ , is not feasible at 298 K. Temperature above which reaction will be feasible is :-

- (1) 1890.0 K
- (2) 2480.3 K
- (3) 2040.5 K
- (4) 2380.5 K

Ans. (2)

Sol.  $T_{eq} = \frac{\Delta H}{\Delta S}$

$$= \frac{491.1 \times 1000}{198}$$

$$= 2480.3 \text{ K}$$

14. Given the equilibrium constant :

$K_C$  of the reaction :

$Cu(s) + 2Ag^+(aq) \rightarrow Cu^{2+}(aq) + 2Ag(s)$  is  $10 \times 10^{15}$ , calculate the  $E_{cell}^0$  of this reaction at 298 K

$$\left[ 2.303 \frac{RT}{F} \text{ at } 298 \text{ K} = 0.059 \text{ V} \right]$$

- (1) 0.04736 V
- (2) 0.4736 V
- (3) 0.4736 mV
- (4) 0.04736 mV

Ans. (2)

Sol.  $E_{cell} = E_{cell}^0 - \frac{0.059}{n} \log Q$

At equilibrium

$$E_{Cell}^0 = \frac{0.059}{2} \log 10^{16}$$

$$= 0.059 \times 8$$

$$= 0.472 \text{ V}$$

15. The hydride that is NOT electron deficient is:-

- (1)  $B_2H_6$
- (2)  $AlH_3$
- (3)  $SiH_4$
- (4)  $GaH_3$

Ans. (3)

Sol. (1)  $B_2H_6$  : Electron deficient  
 (2)  $AlH_3$  : Electron deficient  
 (3)  $SiH_4$  : Electron precise  
 (4)  $GaH_3$  : Electron deficient

16. The standard reaction Gibbs energy for a chemical reaction at an absolute temperature T is given by

$$\Delta_r G^\circ = A - BT$$

Where A and B are non-zero constants. Which of the following is TRUE about this reaction ?

- (1) Exothermic if  $B < 0$
- (2) Exothermic if  $A > 0$  and  $B < 0$
- (3) Endothermic if  $A < 0$  and  $B > 0$
- (4) Endothermic if  $A > 0$

Ans. (4)

Sol. Theory

17.  $K_2HgI_4$  is 40% ionised in aqueous solution. The value of its van't Hoff factor (i) is :-

- (1) 1.8
- (2) 2.2
- (3) 2.0
- (4) 1.6

Ans. (1)

Sol. For  $K_2[HgI_4]$   
 $i = 1 + 0.4(3-1)$   
 $= 1.8$

18. The de Broglie wavelength ( $\lambda$ ) associated with a photoelectron varies with the frequency ( $\nu$ ) of the incident radiation as, [ $\nu_0$  is threshold frequency] :

- (1)  $\lambda \propto \frac{1}{(\nu - \nu_0)^{\frac{3}{2}}}$
- (2)  $\lambda \propto \frac{1}{(\nu - \nu_0)^2}$
- (3)  $\lambda \propto \frac{1}{(\nu - \nu_0)^4}$
- (4)  $\lambda \propto \frac{1}{(\nu - \nu_0)}$

Ans. (2)

Sol. For electron

$$\lambda_{DB} = \frac{h}{\sqrt{2mK.E.}} \quad (\text{de broglie wavelength})$$

By photoelectric effect

$$h\nu = h\nu_0 + KE$$

$$KE = h\nu - h\nu_0$$

$$\lambda_{DB} = \frac{h}{\sqrt{2m \times (h\nu - h\nu_0)}}$$

$$\lambda_{DB} \propto \frac{1}{(\nu - \nu_0)^{\frac{1}{2}}}$$

19. The reaction  $2X \rightarrow B$  is a zeroth order reaction. If the initial concentration of X is 0.2 M, the half-life is 6 h. When the initial concentration of X is 0.5 M, the time required to reach its final concentration of 0.2 M will be :-

- (1) 18.0 h
- (2) 7.2 h
- (3) 9.0 h
- (4) 12.0 h

Ans. (1)

Sol. For zero order

$$[A_0] - [A_t] = kt$$

$$0.2 - 0.1 = k \times 6$$

$$k = \frac{1}{60} \text{ M/hr}$$

$$\text{and } 0.5 - 0.2 = \frac{1}{60} \times t$$

$$t = 18 \text{ hrs.}$$

20. A compound 'X' on treatment with  $Br_2/NaOH$ , provided  $C_3H_9N$ , which gives positive carbylamine test. Compound 'X' is :-

- (1)  $CH_3COCH_2NHCH_3$
- (2)  $CH_3CH_2COCH_2NH_2$
- (3)  $CH_3CH_2CH_2CONH_2$
- (4)  $CH_3CON(CH_3)_2$

Ans. (3)

Sol.



Hoffmann's Bromamide degradation  
 Carbylamine Reaction

Thus [X] must be amide with one carbon more than in amine.

Thus [X] is  $CH_3CH_2CH_2CONH_2$

21. Which of the following compounds will produce a precipitate with  $AgNO_3$  ?

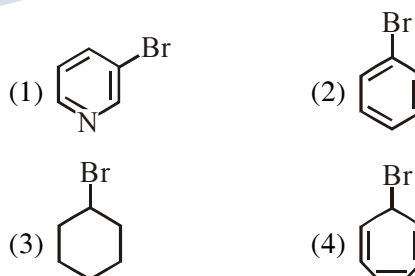

Ans. (4)

Sol.

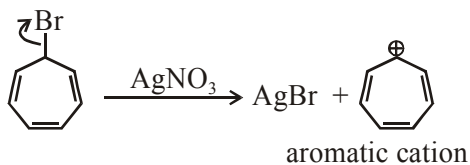

as it can produce aromatic cation so will produce precipitate with  $\text{AgNO}_3$ .

22. The relative stability of +1 oxidation state of group 13 elements follows the order :-

- (1)  $\text{Al} < \text{Ga} < \text{Tl} < \text{In}$  (2)  $\text{Tl} < \text{In} < \text{Ga} < \text{Al}$   
(3)  $\text{Al} < \text{Ga} < \text{In} < \text{Tl}$  (4)  $\text{Ga} < \text{Al} < \text{In} < \text{Tl}$

Ans. (3)

Sol. Due to inert pair effect as we move down the group in 13<sup>th</sup> group lower oxidation state becomes more stable.

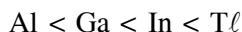

23. Which of the following compounds reacts with ethylmagnesium bromide and also decolourizes bromine water solution :-

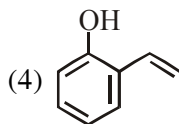
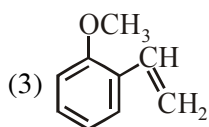
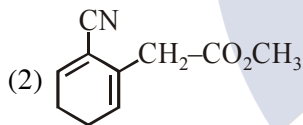
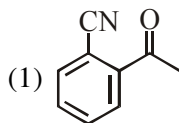

Ans. (4)

Sol.

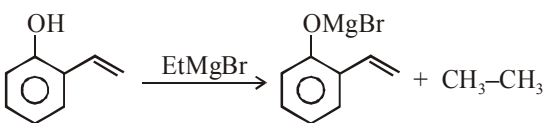

decolourizes Bromine water

24. Match the following items in column I with the corresponding items in column II.

Column I		Column II	
(i)	$\text{Na}_2\text{CO}_3 \cdot 10 \text{H}_2\text{O}$	(A)	Portland cement ingredient
(ii)	$\text{Mg}(\text{HCO}_3)_2$	(B)	Castner-Keller process
(iii)	$\text{NaOH}$	(C)	Solvay process
(iv)	$\text{Ca}_3\text{Al}_2\text{O}_6$	(D)	Temporary hardness

(1) (i)→(C); (ii)→(B); (iii)→(D); (iv)→(A)

(2) (i)→(C); (ii)→(D); (iii)→(B); (iv)→(A)

(3) (i)→(D); (ii)→(A); (iii)→(B); (iv)→(C)

(4) (i)→(B); (ii)→(C); (iii)→(A); (iv)→(D)

Ans. (2)

Sol.  $\text{Na}_2\text{CO}_3 \cdot 10\text{H}_2\text{O} \rightarrow$  Solvay process

$\text{Mg}(\text{HCO}_3)_2 \rightarrow$  Temporary hardness

$\text{NaOH} \rightarrow$  Castner-kellner cell

$\text{Ca}_3\text{Al}_2\text{O}_6 \rightarrow$  Portland cement

25. 25 ml of the given HCl solution requires 30 mL of 0.1 M sodium carbonate solution. What is the volume of this HCl solution required to titrate 30 mL of 0.2 M aqueous NaOH solution?

(1) 25 mL (2) 50 mL (3) 12.5 mL (4) 75 mL

Ans. (1)

Sol. HCl with  $\text{Na}_2\text{CO}_3$

Eq. of HCl = Eq. of  $\text{Na}_2\text{CO}_3$

$$\frac{25}{1000} \times M \times 1 = \frac{30}{1000} \times 0.1 \times 2$$

$$M = \frac{6}{25} M$$

Eq of HCl = Eq. of NaOH

$$\frac{6}{25} \times 1 \times \frac{V}{1000} = \frac{30}{1000} \times 0.2 \times 1$$

$$V = 25 \text{ ml}$$

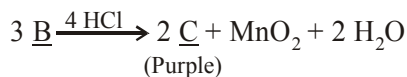
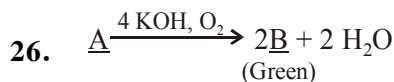

In the above sequence of reactions,

A and D respectively, are :-

- (1)  $\text{KIO}_3$  and  $\text{MnO}_2$       (2)  $\text{KI}$  and  $\text{K}_2\text{MnO}_4$   
(3)  $\text{MnO}_2$  and  $\text{KIO}_3$       (4)  $\text{KI}$  and  $\text{KMnO}_4$

Ans. (3)

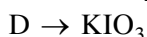
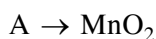
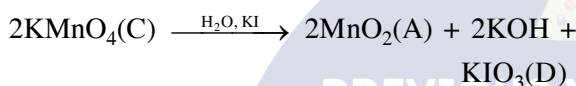
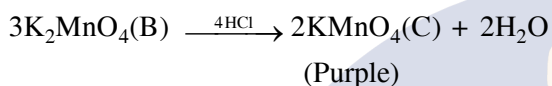
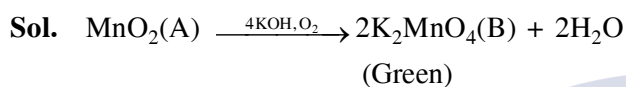

27. The coordination number of Th in  $\text{K}_4[\text{Th}(\text{C}_2\text{O}_4)_4(\text{OH}_2)_2]$  is :-

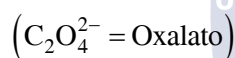

- (1) 6      (2) 10      (3) 14      (4) 8

Ans. (2)

Sol.  $\text{C}_2\text{O}_4^{2-}$  (oxalato) : bidentate

$\text{H}_2\text{O}$  (aqua) : Monodentate

28. The major product obtained in the following reaction is :-

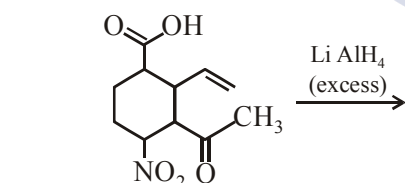

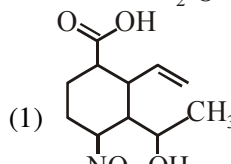
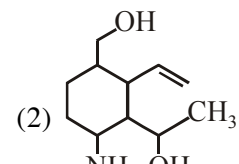
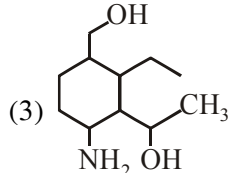
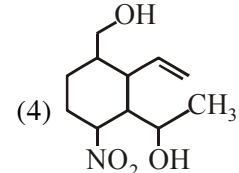
- (1)       (2)   
(3)       (4) 

Ans. (2)

Sol.

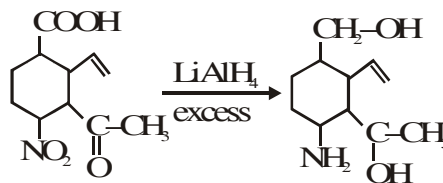

$\text{LiAlH}_4$  will not affect  $\text{C}=\text{C}$  in this compound.

29. The major product of the following reaction is :-

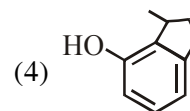
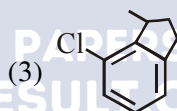
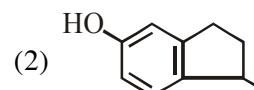
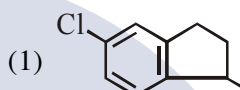
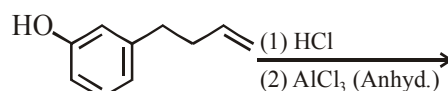

Ans. (2)

Sol.

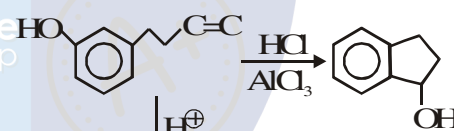

30. For the equilibrium,

$2\text{H}_2\text{O} \rightleftharpoons \text{H}_3\text{O}^+ + \text{OH}^-$ , the value of  $\Delta G^\circ$  at 298 K is approximately :-

- (1)  $-80 \text{ kJ mol}^{-1}$       (2)  $-100 \text{ kJ mol}^{-1}$   
(3)  $100 \text{ kJ mol}^{-1}$       (4)  $80 \text{ kJ mol}^{-1}$

Ans. (4)

Sol.

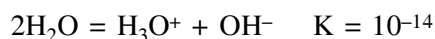

$\Delta G^\circ = -RT \ln K$

$= \frac{-8.314}{1000} \times 298 \times \ln 10^{-14}$

$= 80 \text{ KJ/Mole}$



6. The integral  $\int_{\pi/6}^{\pi/4} \frac{dx}{\sin 2x (\tan^5 x + \cot^5 x)}$  equals :-

(1)  $\frac{1}{10} \left( \frac{\pi}{4} - \tan^{-1} \left( \frac{1}{9\sqrt{3}} \right) \right)$

(2)  $\frac{1}{5} \left( \frac{\pi}{4} - \tan^{-1} \left( \frac{1}{3\sqrt{3}} \right) \right)$

(3)  $\frac{\pi}{10}$

(4)  $\frac{1}{20} \tan^{-1} \left( \frac{1}{9\sqrt{3}} \right)$

Ans. (1)

Sol.  $I = \int_{\pi/6}^{\pi/4} \frac{dx}{\sin 2x (\tan^5 x + \cot^5 x)}$

$I = \frac{1}{2} \int_{\pi/6}^{\pi/4} \frac{\tan^4 x \sec^2 x dx}{(1 + \tan^{10} x)}$  Put  $\tan^5 x = t$

$I = \frac{1}{10} \int_{\left(\frac{1}{\sqrt{3}}\right)^5}^1 \frac{dt}{1+t^2} = \frac{1}{10} \left( \frac{\pi}{4} - \tan^{-1} \frac{1}{9\sqrt{3}} \right)$

7. Let  $(x + 10)^{50} + (x - 10)^{50} = a_0 + a_1x + a_2x^2 + \dots$

+  $a_{50} x^{50}$ , for all  $x \in \mathbb{R}$ , then  $\frac{a_2}{a_0}$  is equal to:-

- (1) 12.50 (2) 12.00 (3) 12.75 (4) 12.25

Ans. (4)

Sol.  $(10 + x)^{50} + (10 - x)^{50}$   
 $\Rightarrow a_2 = 2 \cdot {}^{50}C_2 \cdot 10^{48}$ ,  $a_0 = 2 \cdot 10^{50}$

$\frac{a_2}{a_0} = \frac{{}^{50}C_2}{10^2} = 12.25$

8. Let a function  $f : (0, \infty) \rightarrow (0, \infty)$  be defined by

$f(x) = \left| 1 - \frac{1}{x} \right|$ . Then f is :-

- (1) Injective only  
 (2) Not injective but it is surjective  
 (3) Both injective as well as surjective  
 (4) Neither injective nor surjective

Ans. (Bonus)

Sol.  $f(x) = \left| 1 - \frac{1}{x} \right| = \frac{|x-1|}{x} = \begin{cases} \frac{1-x}{x} & 0 < x \leq 1 \\ \frac{x-1}{x} & x \geq 1 \end{cases}$

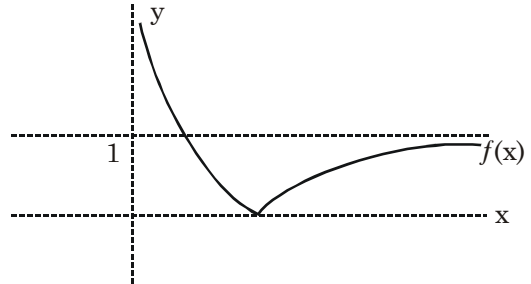

$\Rightarrow f(x)$  is not injective

but range of function is  $[0, \infty)$

Remark : If co-domain is  $[0, \infty)$ , then  $f(x)$  will be surjective

9. Let  $S = \{1, 2, \dots, 20\}$ . A subset B of S is said to be "nice", if the sum of the elements of B is 203. Then the probability that a randomly chosen subset of S is "nice" is :-

- (1)  $\frac{6}{2^{20}}$  (2)  $\frac{5}{2^{20}}$  (3)  $\frac{4}{2^{20}}$  (4)  $\frac{7}{2^{20}}$

Ans. (2)

Sol. 7,

- 1,6  
2,5  
3,4  
1,2,4

$P = \frac{5}{2^{20}}$

10. Two lines  $\frac{x-3}{1} = \frac{y+1}{3} = \frac{z-6}{-1}$  and

$\frac{x+5}{-6} = \frac{y-2}{-4} = \frac{z-3}{4}$  intersect at the point R. The

reflection of R in the xy-plane has coordinates :-

- (1) (2, 4, 7) (2) (-2, 4, 7)  
 (3) (2, -4, -7) (4) (2, -4, 7)

Ans. (3)

Sol. Point on  $L_1$   $(\lambda + 3, 3\lambda - 1, -\lambda + 6)$

Point on  $L_2$   $(7\mu - 5, -6\mu + 2, 4\mu + 3)$

$\Rightarrow \lambda + 3 = 7\mu - 5 \dots(i)$

$3\lambda - 1 = -6\mu + 2 \dots(ii) \Rightarrow \lambda = -1, \mu = 1$

point R(2,-4,7)

Reflection is (2,-4,-7)



**11.** The number of functions  $f$  from  $\{1, 2, 3, \dots, 20\}$  onto  $\{1, 2, 3, \dots, 20\}$  such that  $f(k)$  is a multiple of 3, whenever  $k$  is a multiple of 4, is :-

- (1)  $(15)! \times 6!$                       (2)  $5^6 \times 15$   
 (3)  $5! \times 6!$                       (4)  $6^5 \times (15)!$

**Ans. (1)**

**Sol.**  $f(k) = 3m$  (3,6,9,12,15,18)

for  $k = 4, 8, 12, 16, 20$       6.5.4.3.2 ways

For rest numbers  $15!$  ways

Total ways =  $6!(15)!$

**12.** Contrapositive of the statement "If two numbers are not equal, then their squares are not equal." is :-

- (1) If the squares of two numbers are equal, then the numbers are equal.  
 (2) If the squares of two numbers are equal, then the numbers are not equal.  
 (3) If the squares of two numbers are not equal, then the numbers are equal.  
 (4) If the squares of two numbers are not equal, then the numbers are not equal.

**Ans. (1)**

**Sol.** Contrapositive of  $p \rightarrow q$  is  $\sim q \rightarrow \sim p$

**13.** The solution of the differential equation,

$\frac{dy}{dx} = (x - y)^2$ , when  $y(1) = 1$ , is :-

(1)  $\log_e \left| \frac{2-y}{2-x} \right| = 2(y-1)$

(2)  $\log_e \left| \frac{2-x}{2-y} \right| = x - y$

(3)  $-\log_e \left| \frac{1+x-y}{1-x+y} \right| = x + y - 2$

(4)  $-\log_e \left| \frac{1-x+y}{1+x-y} \right| = 2(x-1)$

**Ans. (4)**

**Sol.**  $x - y = t \Rightarrow \frac{dy}{dx} = 1 - \frac{dt}{dx}$

$$\Rightarrow 1 - \frac{dt}{dx} = t^2 \Rightarrow \int \frac{dt}{1-t^2} = \int 1 dx$$

$$\Rightarrow \frac{1}{2} \ln \left( \frac{1+t}{1-t} \right) = x + \lambda$$

$$\Rightarrow \frac{1}{2} \ln \left( \frac{1+x-y}{1-x+y} \right) = x + \lambda \quad \text{given } y(1) = 1$$

$$\Rightarrow \frac{1}{2} \ln(1) = 1 + \lambda \Rightarrow \lambda = -1$$

$$\Rightarrow \ln \left( \frac{1+x-y}{1-x+y} \right) = 2(x-1)$$

$$\Rightarrow -\ln \left( \frac{1-x+y}{1+x-y} \right) = 2(x-1)$$

**14.** Let  $A$  and  $B$  be two invertible matrices of order  $3 \times 3$ . If  $\det(ABA^T) = 8$  and  $\det(AB^{-1}) = 8$ , then  $\det(BA^{-1}B^T)$  is equal to :-

- (1) 16                      (2)  $\frac{1}{16}$                       (3)  $\frac{1}{4}$                       (4) 1

**Ans. (2)**

**Sol.**  $|A|^2 \cdot |B| = 8$  and  $\frac{|A|}{|B|} = 8 \Rightarrow |A| = 4$  and  $|B| = \frac{1}{2}$

$$\therefore \det(BA^{-1}B^T) = \frac{1}{4} \times \frac{1}{4} = \frac{1}{16}$$

**15.** If  $\int \frac{x+1}{\sqrt{2x-1}} dx = f(x)\sqrt{2x-1} + C$ , where  $C$  is a constant of integration, then  $f(x)$  is equal to :-

(1)  $\frac{1}{3}(x+4)$                       (2)  $\frac{1}{3}(x+1)$

(3)  $\frac{2}{3}(x+2)$                       (4)  $\frac{2}{3}(x-4)$

**Ans. (1)**

**Sol.**  $\sqrt{2x-1} = t \Rightarrow 2x-1 = t^2 \Rightarrow 2dx = 2t \cdot dt$

$$\int \frac{x+1}{\sqrt{2x-1}} dx = \int \frac{\frac{t^2+1}{2} + 1}{t} t dt = \int \frac{t^2+3}{2} dt$$

$$= \frac{1}{2} \left( \frac{t^3}{3} + 3t \right) = \frac{t}{6} (t^2 + 9) + c$$

$$= \sqrt{2x-1} \left( \frac{2x-1+9}{6} \right) + c = \sqrt{2x-1} \left( \frac{x+4}{3} \right) + c$$

$$\Rightarrow f(x) = \frac{x+4}{3}$$

16. A bag contains 30 white balls and 10 red balls. 16 balls are drawn one by one randomly from the bag with replacement. If  $X$  be the number of white balls

drawn, the  $\left(\frac{\text{mean of } X}{\text{standard deviation of } X}\right)$  is equal to :-

- (1) 4      (2)  $\frac{4\sqrt{3}}{3}$       (3)  $4\sqrt{3}$       (4)  $3\sqrt{2}$

Ans. (3)

Sol.  $p$  (probability of getting white ball) =  $\frac{30}{40}$

$$q = \frac{1}{4} \text{ and } n = 16$$

$$\text{mean} = np = 16 \cdot \frac{3}{4} = 12$$

and standard deviation

$$= \sqrt{npq} = \sqrt{16 \cdot \frac{3}{4} \cdot \frac{1}{4}} = \sqrt{3}$$

17. If in a parallelogram  $ABDC$ , the coordinates of  $A$ ,  $B$  and  $C$  are respectively  $(1, 2)$ ,  $(3, 4)$  and  $(2, 5)$ , then the equation of the diagonal  $AD$  is :-

- (1)  $5x + 3y - 11 = 0$       (2)  $3x - 5y + 7 = 0$   
 (3)  $3x + 5y - 13 = 0$       (4)  $5x - 3y + 1 = 0$

Ans. (4)

Sol. co-ordinates of point  $D$  are  $(4, 7)$

$$\Rightarrow \text{line } AD \text{ is } 5x - 3y + 1 = 0$$

18. If a hyperbola has length of its conjugate axis equal to 5 and the distance between its foci is 13, then the eccentricity of the hyperbola is :-

- (1) 2      (2)  $\frac{13}{6}$       (3)  $\frac{13}{8}$       (4)  $\frac{13}{12}$

Ans. (4)

Sol.  $2b = 5$  and  $2ae = 13$

$$b^2 = a^2(e^2 - 1) \Rightarrow \frac{25}{4} = \frac{169}{4} - a^2$$

$$\Rightarrow a = 6 \Rightarrow e = \frac{13}{12}$$

19. The area (in sq. units) in the first quadrant bounded by the parabola,  $y = x^2 + 1$ , the tangent to it at the point  $(2, 5)$  and the coordinate axes is :-

- (1)  $\frac{14}{3}$       (2)  $\frac{187}{24}$       (3)  $\frac{37}{24}$       (4)  $\frac{8}{3}$

Ans. (3)

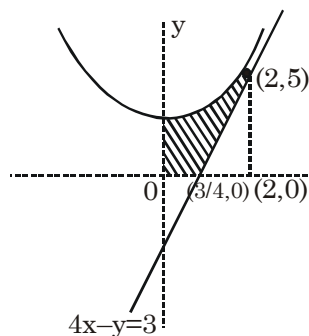

Sol.

$$\text{Area} = \int_0^2 (x^2 + 1) dx - \frac{1}{2} \left(\frac{5}{4}\right)(5) = \frac{37}{24}$$

20. Let  $\sqrt{3}\hat{i} + \hat{j}$ ,  $\hat{i} + \sqrt{3}\hat{j}$  and  $\beta\hat{i} + (1-\beta)\hat{j}$  respectively be the position vectors of the points  $A$ ,  $B$  and  $C$  with respect to the origin  $O$ . If the distance of  $C$  from the bisector of the acute angle between  $OA$  and  $OB$  is  $\frac{3}{\sqrt{2}}$ , then the sum of all possible values of  $\beta$  is :-

- (1) 2      (2) 1      (3) 3      (4) 4

Ans. (2)

Sol. Angle bisector is  $x = y = 0$

$$\Rightarrow \frac{|\beta - (1 - \beta)|}{\sqrt{2}} = \frac{3}{\sqrt{2}}$$

$$\Rightarrow |2\beta - 1| = 3$$

$$\Rightarrow \beta = 2 \text{ or } -1$$

21. If  $\begin{vmatrix} a-b-c & 2a & 2a \\ 2b & b-c-a & 2b \\ 2c & 2c & c-a-b \end{vmatrix} = (a+b+c)(x+a+b+c)^2$ ,  $x \neq 0$  and  $a+b+c \neq 0$ , then  $x$  is equal to :-

- (1)  $-(a+b+c)$       (2)  $2(a+b+c)$   
 (3)  $abc$       (4)  $-2(a+b+c)$

Ans. (4)

$$\text{Sol. } \begin{vmatrix} a-b-c & 2a & 2a \\ 2b & b-c-a & 2b \\ 2c & 2c & c-a-b \end{vmatrix}$$

$$R_1 \rightarrow R_1 + R_2 + R_3$$

$$= \begin{vmatrix} a+b+c & a+b+c & a+b+c \\ 2b & b-c-a & 2b \\ 2c & 2c & c-a-b \end{vmatrix}$$

$$= (a + b + c) \begin{vmatrix} 1 & 0 & 0 \\ 2b & -(a + b + c) & 0 \\ 2c & 2c & c - a - b \end{vmatrix}$$

$$= (a + b + c)(a + b + c)^2$$

$$\Rightarrow x = -2(a + b + c)$$

22. Let  $S_n = 1 + q + q^2 + \dots + q^n$  and

$$T_n = 1 + \left(\frac{q+1}{2}\right) + \left(\frac{q+1}{2}\right)^2 + \dots + \left(\frac{q+1}{2}\right)^n$$

where  $q$  is a real number and  $q \neq 1$ .

If  ${}^{101}C_1 + {}^{101}C_2 \cdot S_1 + \dots + {}^{101}C_{101} \cdot S_{100} = \alpha T_{100}$ , then  $\alpha$  is equal to :-

- (1)  $2^{100}$       (2) 200      (3)  $2^{99}$       (4) 202

Ans. (1)

Sol.  ${}^{101}C_1 + {}^{101}C_2 S_1 + \dots + {}^{101}C_{101} S_{100}$   
 $= \alpha T_{100}$   
 ${}^{101}C_1 + {}^{101}C_2(1 + q) + {}^{101}C_3(1 + q + q^2) + \dots + {}^{101}C_{101}(1 + q + \dots + q^{100})$

$$= 2\alpha \frac{\left(1 - \left(\frac{1+q}{2}\right)^{101}\right)}{(1-q)}$$

$$\Rightarrow {}^{101}C_1(1 - q) + {}^{101}C_2(1 - q^2) + \dots + {}^{101}C_{101}(1 - q^{101})$$

$$= 2\alpha \left(1 - \left(\frac{1+q}{2}\right)^{101}\right)$$

$$\Rightarrow (2^{101} - 1) - ((1 + q)^{101} - 1)$$

$$= 2\alpha \left(1 - \left(\frac{1+q}{2}\right)^{101}\right)$$

$$\Rightarrow 2^{101} \left(1 - \left(\frac{1+q}{2}\right)^{101}\right) = 2\alpha \left(1 - \left(\frac{1+q}{2}\right)^{101}\right)$$

$$\Rightarrow \alpha = 2^{100}$$

23. A circle cuts a chord of length  $4a$  on the  $x$ -axis and passes through a point on the  $y$ -axis, distant  $2b$  from the origin. Then the locus of the centre of this circle, is :-

- (1) A hyperbola      (2) A parabola  
 (3) A straight line      (4) An ellipse

Ans. (2)

Sol. Let equation of circle is

$$x^2 + y^2 + 2fx + 2fy + e = 0, \text{ it passes through } (0, 2b)$$

$$\Rightarrow 0 + 4b^2 + 2g \times 0 + 4f + c = 0$$

$$\Rightarrow 4b^2 + 4f + c = 0 \quad \dots(i)$$

$$2\sqrt{g^2 - c} = 4a \quad \dots(ii)$$

$$g^2 - c = 4a^2 \Rightarrow c = (g^2 - 4a^2)$$

Putting in equation (1)

$$\Rightarrow 4b^2 + 4f + g^2 - 4a^2 = 0$$

$\Rightarrow x^2 + 4y + 4(b^2 - a^2) = 0$ , it represent a parabola.

24. If 19th term of a non-zero A.P. is zero, then its (49th term) : (29th term) is :-

- (1) 3 : 1      (2) 4 : 1      (3) 2 : 1      (4) 1 : 3

Ans. (1)

Sol.  $a + 18d = 0 \quad \dots(1)$

$$\frac{a + 48d}{a + 28d} = \frac{-18d + 48d}{-18d + 28d} = \frac{3}{1}$$

25. Let  $f(x) = \frac{x}{\sqrt{a^2 + x^2}} - \frac{d - x}{\sqrt{b^2 + (d - x)^2}}$ ,  $x \in \mathbb{R}$ , where  $a, b$  and  $d$  are non-zero real constants.

Then :-

- (1)  $f$  is a decreasing function of  $x$   
 (2)  $f$  is neither increasing nor decreasing function of  $x$   
 (3)  $f$  is not a continuous function of  $x$   
 (4)  $f$  is an increasing function of  $x$

Ans. (4)

Sol.  $f(x) = \frac{x}{\sqrt{a^2 + x^2}} - \frac{d - x}{\sqrt{b^2 + (d - x)^2}}$

$$f'(x) = \frac{a^2}{(a^2 + x^2)^{3/2}} + \frac{b^2}{(b^2 + (d - x)^2)^{3/2}} > 0 \forall x \in \mathbb{R}$$

$f(x)$  is an increasing function.

26. Let  $z$  be a complex number such that  $|z| + z = 3 + i$  (where  $i = \sqrt{-1}$ ). Then  $|z|$  is equal to :-

- (1)  $\frac{5}{4}$       (2)  $\frac{\sqrt{41}}{4}$       (3)  $\frac{\sqrt{34}}{3}$       (4)  $\frac{5}{3}$

Ans. (4)

Sol.  $|z| + z = 3 + i$

$$z = 3 - |z| + i$$

$$\text{Let } 3 - |z| = a \Rightarrow |z| = (3 - a)$$

$$\Rightarrow z = a + i \Rightarrow |z| = \sqrt{a^2 + 1}$$

$$\Rightarrow 9 + a^2 - 6a = a^2 + 1 \Rightarrow a = \frac{8}{6} = \frac{4}{3}$$

$$\Rightarrow |z| = 3 - \frac{4}{3} = \frac{5}{3}$$

27. All  $x$  satisfying the inequality  $(\cot^{-1} x)^2 - 7(\cot^{-1} x) + 10 > 0$ , lie in the interval:-  
 (1)  $(-\infty, \cot 5) \cup (\cot 4, \cot 2)$   
 (2)  $(\cot 5, \cot 4)$   
 (3)  $(\cot 2, \infty)$   
 (4)  $(-\infty, \cot 5) \cup (\cot 2, \infty)$

**Ans. (4)**

**Sol.**  $\cot^{-1} x > 5, \cot^{-1} x < 2$   
 $\Rightarrow x < \cot 5, x > \cot 2$

28. Given  $\frac{b+c}{11} = \frac{c+a}{12} = \frac{a+b}{13}$  for a  $\Delta ABC$  with

usual notation. If  $\frac{\cos A}{\alpha} = \frac{\cos B}{\beta} = \frac{\cos C}{\gamma}$ , then

the ordered triad  $(\alpha, \beta, \gamma)$  has a value :-

- (1) (3, 4, 5) (2) (19, 7, 25)  
 (3) (7, 19, 25) (4) (5, 12, 13)

28. **Ans. (3)**

**Sol.**  $b + c = 11\lambda, c + a = 12\lambda, a + b = 13\lambda$

$\Rightarrow a = 7\lambda, b = 6\lambda, c = 5\lambda$

(using cosine formula)

$$\cos A = \frac{1}{5}, \cos B = \frac{19}{35}, \cos C = \frac{5}{7}$$

$$\alpha : \beta : \gamma \Rightarrow 7 : 19 : 25$$

29. Let  $x, y$  be positive real numbers and  $m, n$  positive integers. The maximum value of the expression

$$\frac{x^m y^n}{(1+x^{2m})(1+y^{2n})} \text{ is :-}$$

- (1)  $\frac{1}{2}$  (2)  $\frac{1}{4}$  (3)  $\frac{m+n}{6mn}$  (4) 1

**Ans. (2)**

**Sol.** 
$$\frac{x^m y^n}{(1+x^{2m})(1+y^{2n})} = \frac{1}{\left(x^m + \frac{1}{x^m}\right)\left(y^n + \frac{1}{y^n}\right)} \leq \frac{1}{4}$$

using  $AM \geq GM$

30.  $\lim_{x \rightarrow 0} \frac{x \cot(4x)}{\sin^2 x \cot^2(2x)}$  is equal to :-

- (1) 2 (2) 0 (3) 4 (4) 1

**Sol.** 
$$\lim_{x \rightarrow 0} \frac{x \tan^2 2x}{\tan 4x \sin^2 x} = \lim_{x \rightarrow 0} \frac{x \left(\frac{\tan^2 2x}{4x^2}\right) 4x^2}{\left(\frac{\tan 4x}{4x}\right) 4x \left(\frac{\sin^2 x}{x^2}\right) x^2} = 1$$